



# **NSR12N - NSR16N - NSR16NI - NSR20N**

Specifications

**Stand on Stacker**

1.2 - 2.0 tonnes

Characteristics			Cat Lift Trucks	Cat Lift Trucks	Cat Lift Trucks	Cat Lift Trucks
1.01	Manufacturer (abbreviation)		NSR12N	NSR16N	NSR16NI	NSR20N
1.02	Manufacturer's model designation		Battery	Battery	Battery	Battery
1.03	Power source: (battery, diesel, LP gas, petrol)		Stand-on	Stand-on	Stand-on	Stand-on
1.04	Operator type: pedestrian, (operator)-standing, -seated					
1.05	Load capacity	Q (kg)	1200	1600	1600	2000
1.06	At load centre	c (mm)	600	600	600	600
1.08	Load wheel axle to fork face (forks lowered)	x (mm)	775	775	760	805
1.09	Wheelbase	y (mm)	1440	1440	1460	1595
Weight						
2.01	Truck weight with nominal load & battery	kg	2775*	3175*	3255*	4415*
2.02	Axle loadings with nominal load & battery, drive/load side	kg	1255 / 1520*	1295 / 1880*	1335 / 1920*	1750 / 2485*
2.03	Axle loadings without load & with battery, drive/load side	kg	1130 / 445*	1130 / 445*	1170 / 485*	1540 / 695*
Wheels, Drive Train						
3.01	Tires: P=Polyurethane, PT=Power Thane, Vul=Vulkollan, drive/load side		Vul / Vul	Vul / Vul	Vul / Vul	Vul / Vul
3.02	Tire dimensions, front		250 x 100	250 x 100	250 x 100	250 x 100
3.03	Tire dimensions, rear		85 x 75	85 x 75	85 x 75	85 x 90
3.04	Castor wheel dimensions (diameter x width)		150 x 50	150 x 50	150 x 50	150 x 50
3.05	Number of wheels, front/rear (x=driven)		1x + 2 / 4	1x + 2 / 4	1x + 2 / 4	1x + 2 / 4
3.06	Track width (center of tires), load side	b10 (mm)	385	385	385	375
3.07	Track width (center of tires), drive side	b11 (mm)	595	595	595	595
Dimensions						
4.02	Height with mast lowered	h1 (mm)	2385*	2385*	2500*	2710*
4.03	Free lift (see tables)	h2 (mm)	1815*	1815*	1815*	2060*
4.04	Lift height (see tables)	h3 (mm)	5400*	5400*	5400*	6300*
4.05	Overall height with mast raised	h4 (mm)	5940*	5940*	6055*	7130*
4.06	Initial lift	h5 (mm)	-	-	115	-
4.07	Height to top of overhead guard	h6 (mm)	2300	2300	2300	2300
4.08	Platform height	h7 (mm)	235	235	235	235
4.15	Fork height, fully lowered	h13 (mm)	90	90	92	90
4.19	Overall length	l1 (mm)	2000	2000	2050	2160
4.20	Length to fork face (includes fork thickness)	l2 (mm)	850	850	900	1010
4.21	Overall width	b1 / b2 (mm)	890 / 1440**	890 / 1440**	890 / 1440**	890 / 1510**
4.22	Fork dimensions (thickness, width, length)	s / e / l (mm)	65 / 165 / 1150	65 / 165 / 1150	65 / 185 / 1150	65 / 195 / 1150
4.25	Outside width over forks (minimum/maximum)	b5 (mm)	550 - 685	550 - 685	570 - 685	570 - 685
4.32	Ground clearance at centre of wheelbase (forks lowered)	m2 (mm)	20	20	20	20
4.33/a	Working aisle width (Ast) with 1000 x 1200 mm pallets, load crosswise	Ast (mm)	2506	2506	2546	2651
4.33/b	Working aisle width (Ast3) with 1000 x 1200 mm pallets, load crosswise	Ast3 (mm)	2090	2090	2140	2215
4.34/a	Working aisle width (Ast) with 800 x 1200 mm pallets, load lengthwise	Ast (mm)	2449	2449	2495	2582
4.34/b	Working aisle width (Ast3) with 800 x 1200 mm pallets, load lengthwise	Ast3 (mm)	2290	2290	2340	2415
4.35	Turning circle radius	Wa (mm)	1665	1665	1700	1820
Performance						
5.01	Travel speed, with/without load	km/h	7.0 / 8.0	7.0 / 8.0	7.0 / 8.0	6.5 / 7.5
5.02	Lifting speed, with/without load	m/s	0.17 / 0.31	0.13 / 0.31	0.13 / 0.31	0.11 / 0.31
5.03	Lowering speed, with/without load	m/s	0.5 / 0.35	0.5 / 0.35	0.5 / 0.35	0.5 / 0.40
5.07	Gradeability, with/without load	%	7 / 10	7 / 10	7 / 10	6 / 10
5.10	Service brakes (mechanical/hydraulic/electric/pneumatic)		electric	electric	electric	electric
Electric motors						
6.01	Drive motor capacity (60 min. short duty)	kW	2.2	2.2	2.2	2.2
6.02	Lift motor output at 15% duty factor	kW	5.5	5.5	5.5	5.5
6.04	Battery voltage/capacity at 5-hour discharge	V/Ah	24 / 375	24 / 375	24 / 375	24 / 575 - 625
6.05	Battery weight	kg	305	305	305	435 - 465
Miscellaneous						
8.01	Type of drive control		stepless	stepless	stepless	stepless
8.04	Noise level, mean value at operator's ear	dB(A)	68	68	68	62

\* With TREV 5400 mm mast on 1200 and 1600 Kg models, 6300 mm mast on 2000 Kg model

\*\* Without / with stabilizers extended



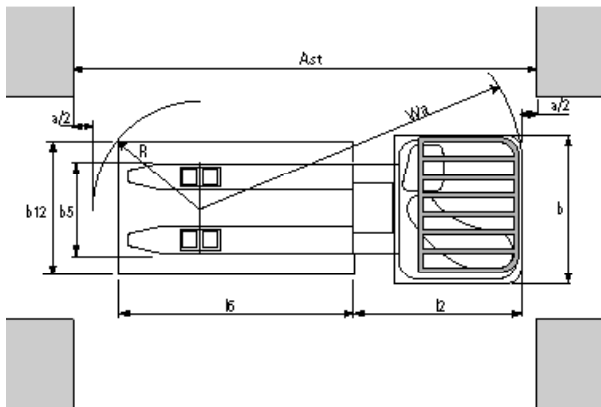
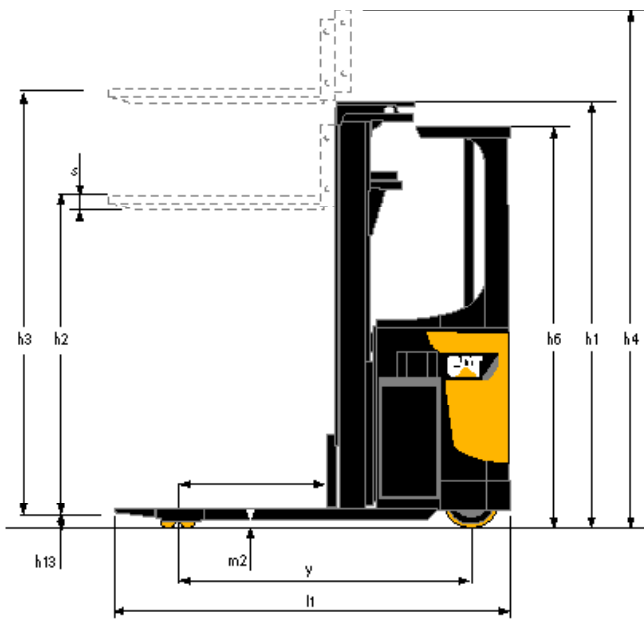

$A_{st} = W_a + R + a$   
 $A_{st}$  = working aisle width  
 $W_a$  = Turning radius  
 $a$  = Safety clearance =  $2 \times 100$  mm  
 $R = \sqrt{(l_6 - x)^2 + (b_{12} / 2)^2}$

## Lower Cost of Ownership

- Smooth, progressive, with easy to use controls enhancing operator concentration leading to better shift productivity.
- AC-drive technology means longer service intervals, reducing the total cost of ownership.
- Battery discharge indicator (BDI) incorporates lift cut-out for battery protection.

## Unmatched Productivity

- The NSR12N NSR16N and NSR20N are compact stand on stackers, designed for horizontal movement over long distances and applications where the operator needs frequent and easy on-off access.
- Ideal for work in aisles too narrow for reach trucks, these stackers are precision engineered for fast travel and fast lifting speeds that guarantee high productivity lifting loads up to 6500mm (with Triplex mast).
- Extendable side stabilizers are available for a high residual capacity at elevated heights (standard with Triplex masts, optional on duplex).
- Fast acceleration and excellent maneuverability giving high productivity.
- Initial lift models for increased ground clearance, making the truck suitable for working on ramps.
- Standard PIN code start-up, and driver specific settings.
- Programmable features for driver.
- Regenerative braking feeds power back into the battery.
- LCD display with all relevant information (Drive wheel direction, driving speed, battery discharge, errors and warnings, service access).
- AC drive gives smooth control, rapid acceleration and a high drive speed (with or without load).
- Smooth hydraulics, proportional lifting & lowering.
- Highly maneuverable with a small turning radius.
- High residual capacities, especially with side stabilizers.
- Fold open battery compartment for easy access.
- Battery roller as standard for quick battery change.
- Rounded fork tips for easy pallet entry, when approaching at an angle.
- Easy to operate driver's menu.

## Awareness and Ergonomics

- Progressive steering gives excellent maneuverability at low speeds and stability at high speed.
- Ergonomically designed electronic 360° fly-by-wire steering gives precise control at speed.
- Good all-round visibility.
- Low step-in and good on-off access.
- Automatic speed reduction in curves, for safe and secure handling.
- Automatic speed reduction as lift height is increased.
- Suspended drivers platform for driver comfort.

## Options

- Various fork lengths.
- Side plates can be customized.
- Various mast types (duplex, triplex with or without free lift).
- Side stabilizers for extra residual capacity on simplex & duplex masts.
- Compulsory lowering of side stabilizers at 2.5 m lift height or higher.
- Choice of different wheel materials.
- Joystick control.
- Warning light & drive alarm.
- List bracket or PC support.
- Key switch instead of start/stop button.



# Cat® Lift Trucks.

Your partner in materials handling.

NSR12N				
Mast Type	h1 mm	h4 mm	h2+h13 mm	(h2+h13) mm
S	1950	1950	1500	-
DS/DEV	1835	3000	200	1365
	2035	3400	200	1565
	2235	3800	200	1765
	2310	3950	200	1840
	2385	4100	200	1915
TR/TREV	2735	4800	200	2265
	2385	5940	-	1900
	2555	6440	-	2070
	2755	7040	-	2270

NSR16N				
Mast Type	h1 mm	h4 mm	h2+h13 mm	(h2+h13) mm
S	1950	1950	1500	-
DS/DEV	1835	3000	200	1365
	2035	3400	200	1565
	2235	3800	200	1765
	2310	3950	200	1840
	2385	4100	200	1915
TR/TREV	2735	4800	200	2265
	2385	5940	-	1900
	2555	6440	-	2070
	2755	7040	-	2270

NSR20N				
Mast Type	h1 mm	h4 mm	h2+h13 mm	(h2+h13) mm
TF	2210	5630	-	1650
	2410	6230	-	1850
	2510	6530	-	1950
	2577	6730	-	2017
	2710	7130	-	2150

NSR16NI					
Mast Type	h3+h13 mm	h1 mm	h4 mm	h2+h13 mm	(h2+h13) mm
S	1500	2065	2065	1500	-
DS/DEV	2500	1950	3115	200	1365
	2900	2150	3515	200	1565
	3300	2350	3915	200	1765
	3450	2425	4065	200	1840
	3600	2500	4215	200	1915
	4300	2850	4915	200	2265
TR/TREV	5400	2500	6055	-	1900
	5900	2670	6555	-	2070
	6500	2870	7155	-	2270

## Mast Performance and Capacity

- S Simplex
- DS Duplex with Clear View Mast
- DEV Duplex with Full Free Lift
- TR Triplex with Clear View Mast
- TREV Triplex with Full Free Lift
- TF Triplex with Integral Mast
- h3+h13 Lift height
- h1 Lowered mast height (with initial lift + 115 mm)
- h4 Raised mast height (with initial lift + 115 mm)
- h2+h13 Free lift height
- (h2+h13)\* Special free lift height

catliftruck@mcf.nl  
www.catliftruck.com

WESC0870(10/07)ok  
Copyright ©2007, MCFE. All rights reserved.  
CAT, CATERPILLAR, their respective logos and 'Caterpillar Yellow', as well as corporate and product identity used herein, are trademarks of Caterpillar and may not be used without permission.  
Printed in The Netherlands

NOTE: Performance specifications may vary depending on standard manufacturing tolerances, vehicle condition, types of tires, floor or surface conditions, applications, or operating environment. Trucks may be shown with non-standard options. Specific performance requirements and locally available configurations should be discussed with your Cat lift trucks Dealer. Cat Lift Trucks follows a policy of continual product improvement. For this reason, some materials, options and specifications could change without notice.

